

100GHz Dual Channel OADM



ACP's 100 GHz 2 Channel OADM utilizes thin film coating technology and proprietary design of non-flux metal bonding micro optics packaging to achieve optical add and drop at the ITU wavelength. It provides ITU channel center wavelength, low insertion loss, high channel isolation, wide pass band, low temperature sensitivity and epoxy free optical path. It can be used for wavelength add/drop in telecommunication network system.

All AC Photonics' products are Telcordia qualification tested.

Key Features

- 100GHz ITU Channel Spacing
- Low Insertion Loss
- Wide Pass Band
- High Channel Isolation
- High Stability and Reliability
- Epoxy Free Optical Path

Applications

- Channel Add / Drop
- DWDM Network
- Wavelength Routing
- Fiber Optical Amplifier
- CATV Fiberoptic System

Performance Specifications

Parameter		Specifications	
		Mux	Demux
Channel Wavelength		1530.33 to 1560.61 (21~ 59 ITU grid)	
Center Wavelength Accuracy		± 0.05nm	
Minimum Channel Spacing		100GHz	
Channel Passband (@-0.5dB bandwidth)		≥ 0.22nm	
Insertion Loss	Add / Drop Ch 1.	≤ 1.2dB	≤ 1.2dB
	Add / Drop Ch 2.	≤ 1.5dB	≤ 1.5dB
	Express Ch.	≤ 1.4dB	≤ 1.4dB
Add / Drop Channel Ripple		≤ 0.3dB	≤ 0.3dB
Channel Isolation	Adjacent	N/A	≥ 25dB
	Non-adjacent	N/A	≥ 40dB
Express Channel Isolation		≥ 25dB	
Insertion Loss Temperature Sensitivity		≤ 0.003dB/°C	
Wavelength Temperature Shifting		≤ 0.002nm/°C	
Polarization Dependent Loss		≤ 0.10dB	
Polarization Mode Dispersion		≤ 0.10ps	
Directivity		≥ 50dB	
Return Loss		≥ 45dB	
Optical Power		≤ 300mW	
Operating Temperature		0 to +70°C	
Storage Temperature		-40 to +85°C	
Package Dimensions		L80mm x W50mm x H6.0mm	

Mechanical Dimensions

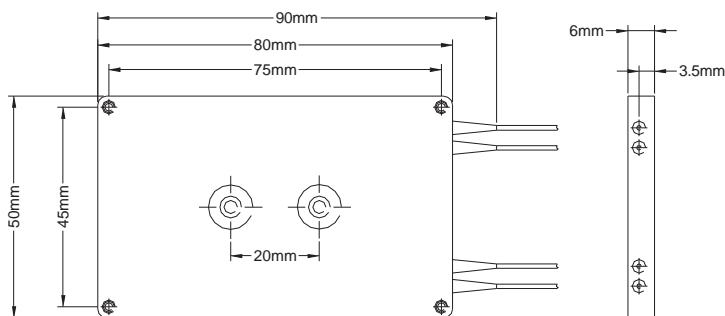

Spectral Chart

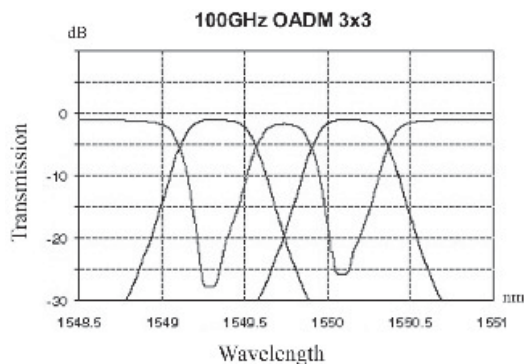

Ordering Information

OADM	<input type="checkbox"/>	<input type="checkbox"/> <input type="checkbox"/>	<input type="checkbox"/> <input type="checkbox"/> <input type="checkbox"/>	<input type="checkbox"/>	<input type="checkbox"/>	<input type="checkbox"/> <input type="checkbox"/>
	Channel Spacing	Number of Channel	ITU Channel	Pigtail Style	Fiber Length	In/Out Connector
	1 = 100GHz	02 = 2 Channel	C21 = 1560.61nm C22 = 1559.79nm C23 = 1558.98nm	1 = Bare Fiber 2 = 900um Jacket 3 = 3mm Cable 4 = 2mm Cable	1 = 1.0m 2 = 2.0m	0 = None 1 = FC/APC 2 = FC/PC 3 = SC/APC 4 = SC/PC 5 = ST 6 = LC/UPC 7 = LC/APC